



Belvac Production Machinery Technical Bulletin

Information for Customers Operating & Maintaining Belvac Machines

ISSUE 04 VOL. 4 October 2001

New Necker Turret Face Seal Manifold

Belvac introduces an innovative, new Necker Turret Face Seal Manifold (FSM) (*Patent Applied For*) for all 595 Model Necker machinery (non-K, K, & SK) to enable customers to significantly reduce ever-increasing utility costs.

These assemblies have been production tested on all necking stages of a 595 Model Necker, at 1900 CPM, with a dramatic 30% - 50% reduction in overall machine air consumption. The comparison was made against all stages of the same machine utilizing Belvac's *newest* Lift-Off Air Manifolds. In addition, a similar face seal design has three years production experience on another Belvac model Necker.

The overall air consumption savings a customer experiences will depend on the model and condition of their existing manifolds, and the high, medium and low regulator pressure settings of the new FSM.

With the Face Seal Manifold properly installed (*complete instructions and drawing included with purchase*) the total air requirement per Belvac 595 Necking Station will be 80 SCFM (2.32 m³/min) @ 60 PSIG (414 KPa). Belvac's recommended pressure settings are 30 PSI high, 10 PSI medium (fixed) and 10 PSI low.

Belvac is pleased to provide a **full three year manufacturer's warranty** (free of design defects, workmanship, or material, when assembly is subjected to normal conditions and installed properly).

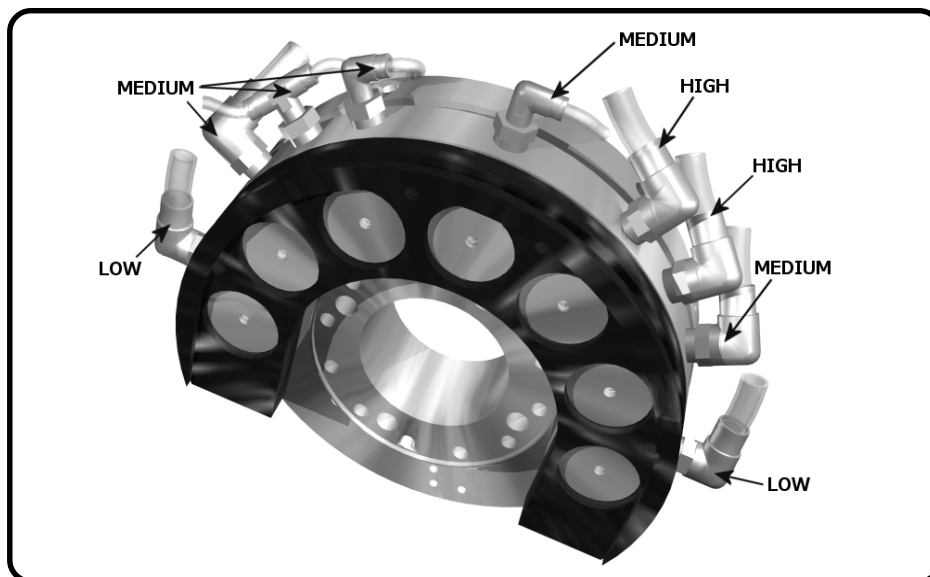

Design features of the **Face Seal Manifold** include:

- Low, Medium, and High Ports efficiently utilize supplied air
- May be directly retro-fitted to 595 non-K, K, and SK model neckers

continued on back...

 **Belvac
Production
Machinery, Inc.**
A DOVER COMPANY
Precision Leadership

237 Graves Mill Road, Lynchburg, Va. 24502 USA

Tel. (434) 239-0358 Fax (434) 239-1964

info@belvac.com

<http://www.belvac.com>

- Floating pistons accommodate shaft adjustments (neck depth changes)
- Manifold plate is piloted to the Knockout Cam for accurate location
- Closed loop piston priming from main air supply
- Adjustable timing to accommodate specific Die-to-Can contact position (Timing is achieved by simply releasing retainer screws and rotating manifold position)
- Rotor is split for ease of maintenance and installation
- Suited for both 1.375" (34.93 mm) and 1.500" (38.1 mm) Cam Strokes

The Face Seal Manifold Retrofit Kit may be ordered as follows:

- 104045 Face Seal Manifold Asm -- 595 non-K and K Fixed Base Neckers**
- 104050 Face Seal Manifold Asm -- 595K Modular Neckers**
- 104057 Face Seal Manifold Asm -- 595SK Modular Neckers**
- 104055 Wrench Installation Tool***

This manifold will become standard on all new Belvac Necker Machines and Add-On Necker Turrets shipped after January 01, 2002.

The Lift-Off Air Manifold design will remain available as spares for a very limited time. Belvac will notify customers by Technical Bulletin of this design's obsolescence.

**For ease of installation, Belvac recommends wrench #104055 be purchased on a per machine basis. This wrench does not come standard with every kit. Please purchase separately.*

Please contact Sales & Service at Belvac or e-mail at info@belvac.com for more information.